

STAND UP *motorized*

Cod. PEPLIV2190-XXX

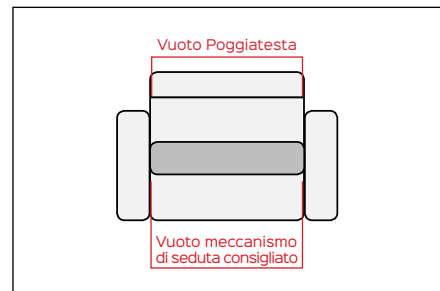

DESIGN IN MOVIMENTO



Vuoto standard (mm)	
Vuoto Meccanismo di seduta consigliato	Vuoto Poggiatesta
540	370
650	480
730	560
800	630
880	710

Oltre 30 misure disponibili

Elettrico	3,40kg +/- 500gr	102°-212°	Poltrone	Divani	Portata: 15kg	Cicli: 30.000	2 ANNI Meccanismo 2 ANNI Attuatore Garanzia
-----------	------------------	-----------	----------	--------	---------------	---------------	---

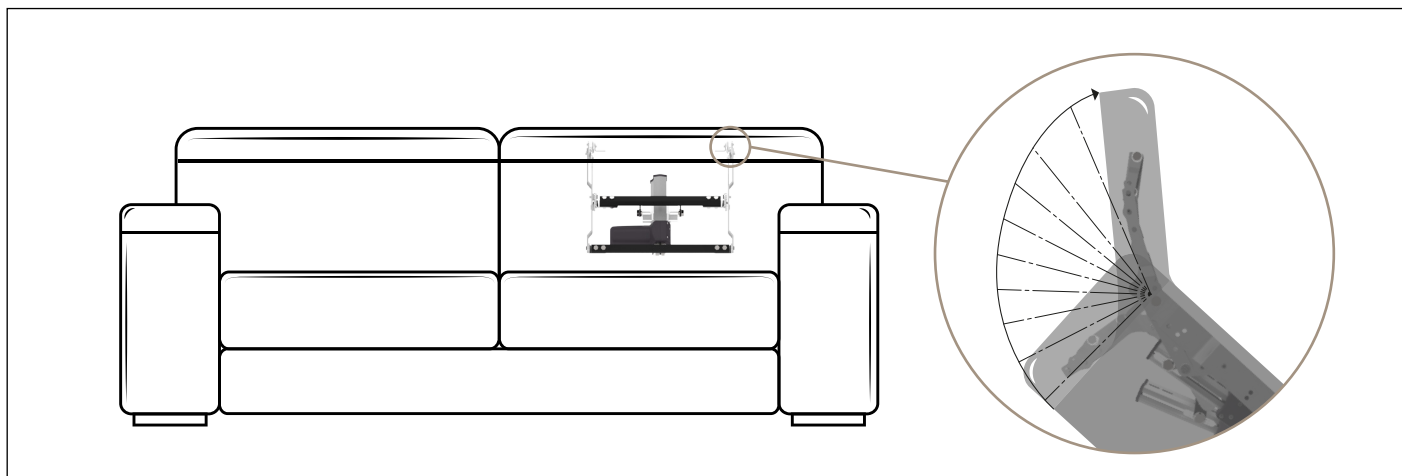

Benefit: Il poggiatesta elettrico è completamente foderato all'interno del divano, la struttura estremamente compatta ha le seguenti caratteristiche: rotazione 110°, alzata 179mm, traslazione 121mm. L'alta qualità dei

materiali e delle componenti elettriche utilizzate rendono questa meccanica efficiente e duratura. Il supporto cervicale garantisce una corretta postura dell'utente dalla posizione tv alla posizione relax.

Optional

KIT ELETTRICI	
	ATTUATORI
SPINE E PROLUNGHE	ALIMENTATORI E BATTERIE

SISTEMI DI CONTROLLO		
	INCASSO	PIASTRE
TOUCH SENSOR	TELECOMANDI	CONTROLLO IPAD/IPOD

Motionitalia Design and quality Made in Italy

Headquarters: via Navicella 26, 47122 Forlì (FC) Tel. +39 0543 77 47 68 Fax. +39 0543 79 84 09 www.motionitalia.com info@motionitalia.com

Il produttore si riserva il diritto di modificare, in qualsiasi momento e senza preavviso, le specifiche tecniche dei propri prodotti

STAND UP *motorized*

Code PEPLIV2190-XXX



DESIGN IN MOVIMENTO

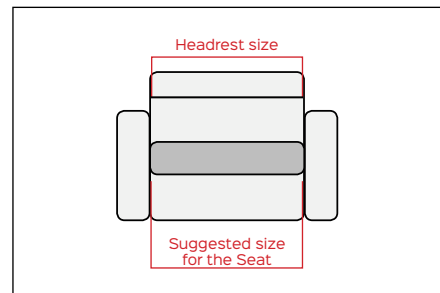

Standard sizes (mm)	
Suggested size for the Seat	Headrest size
540	370
650	480
730	560
800	630
880	710

More than **30** measures available

Motorized	3,40kg +/-500gr	102°-212°	Armchairs	Sofas	Load:15kg	Cycles:30.000	2YEARS Mechanism 2YEARS Actuator Warranty
-----------	-----------------	-----------	-----------	-------	-----------	---------------	---

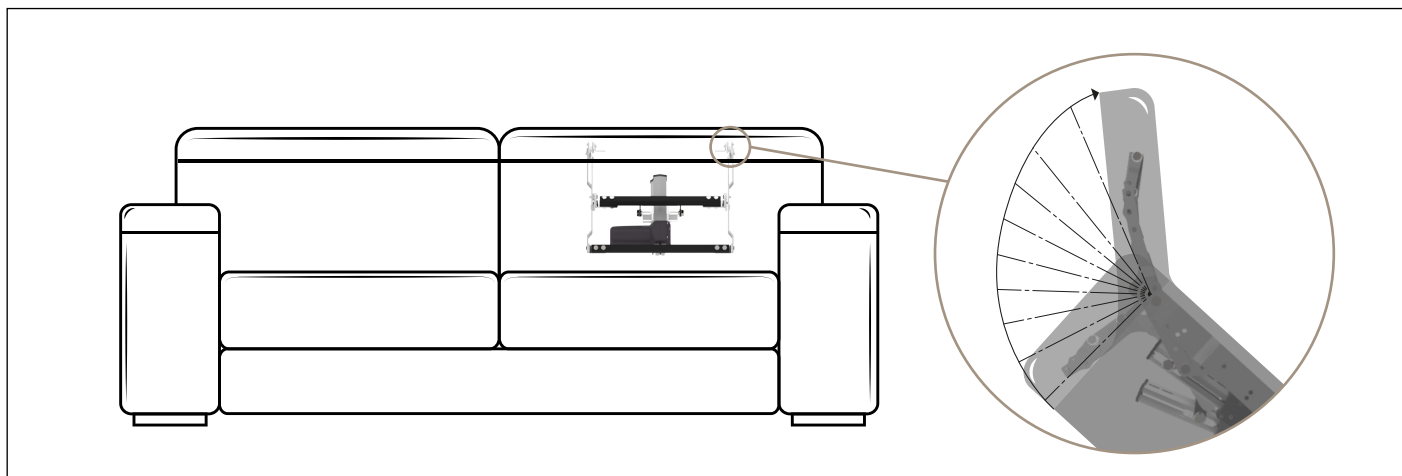

Benefit: This motorized headrest is fully upholstered inside the sofa. The very slim structure has the following features: 110° rotation, 179mm shift and 121mm translation.

High quality materials and electric kit make this mechanism highly efficient and long-lasting. Cervical support offers the right posture to the user from Tv position to relax position.

Optional

ELECTRIC KIT	ACTUATORS
PLUGS & CABLE EXTENSIONS	POWER SUPPLY & BATTERY PACKS

CONTROL SYSTEM	BUILT IN SWITCHES	CONTROL PLATES
TOUCH SENSOR	REMOTES	IPAD/IPOD CONTROL SYSTEM

Motionitalia Design and quality Made in Italy

Headquarters: via Navicella 26, 47122 Forlì (FC) Tel.+39 0543 77 47 68 Fax.+39 0543 79 84 09 www.motionitalia.com info@motionitalia.com

The producer reserves the right to modify, at any moment and without notice, the technical specification of its products