

# SCHIENALETTO *motorized*



DESIGN IN MOVIMENTO



Vuoto schienale consigliato

Vuoto standard (mm)	
Vuoto schienale consigliato	540
	650
	730
	800
	880

Elettrico	7,5Kg +/- 500g	XXX mm	Poltrone	Divani	Portata: 30kg	Cicli: 30.000	2 ANNI Meccanismo 2 ANNI Attuatore Garanzia
-----------	----------------	--------	----------	--------	---------------	---------------	---

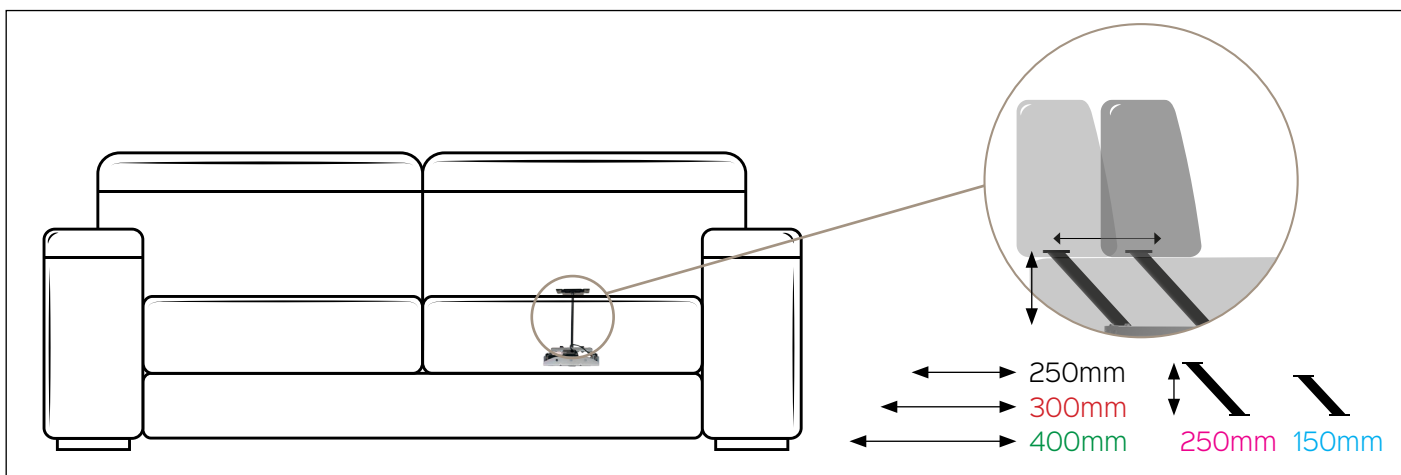

**Benefit:** SCHIENALETTO motorized è un prodotto versatile, affidabile e disponibile in differenti configurazioni. Il supporto schienale permette infatti di aumentare la seduta dell'imbottito, cambiando le peculiarità dello stesso in base alle esigenze del momento.

Le corse disponibili sono: 250mm, 300mm, 400mm. L'avanzamento motorizzato permette di raggiungere facilmente innumerevoli posizioni di comfort tra inizio e fine corsa del prodotto, soddisfacendo le più svariate esigenze del cliente finale.

## Optional

CONFIGURAZIONI CORSA ↔ 250mm	CONFIGURAZIONI ALTEZZA ↕ 250mm	KIT ELETTRICI ATTUATORI	SISTEMI DI CONTROLLO INCASSO PIASTRE
↔ 300mm	↕ 150mm	SPINE E PROLUNGHE ALIMENTATORI E BATTERIE	TOUCH SENSOR TELECOMANDI CONTROLLO IPAD/IPOD

**Motionitalia Design and quality Made in Italy**

Headquarters: via Navicella 26, 47122 Forlì (FC) Tel. +39 0543 77 47 68 Fax. +39 0543 79 84 09 [www.motionitalia.com](http://www.motionitalia.com) [info@motionitalia.com](mailto:info@motionitalia.com)

Il produttore si riserva il diritto di modificare, in qualsiasi momento e senza preavviso, le specifiche tecniche dei propri prodotti

# SCHIENALETTO *motorized*



DESIGN IN MOVIMENTO

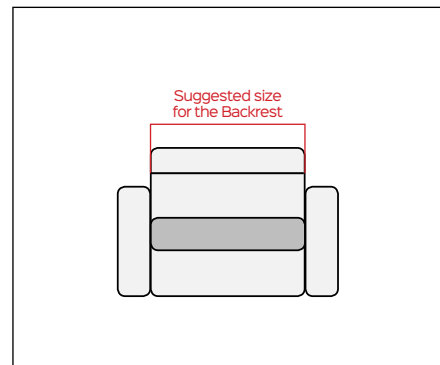

Standard sizes (mm)	
Suggested size for the Backrest	
540	
650	
730	
800	
880	

Motorized	7,5Kg +/- 500g	XXX mm	Armchairs	Sofas	Load: 30kg	Cycles: 30.000	2 YEARS Mechanism 2 YEARS Actuator Warranty
-----------	----------------	--------	-----------	-------	------------	----------------	---

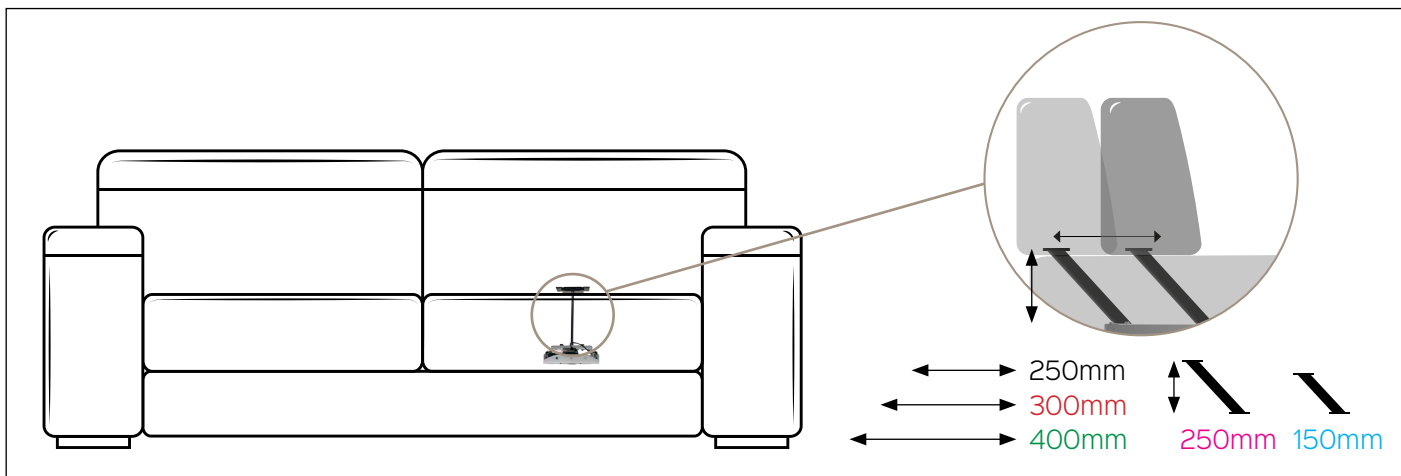

**Benefit:** SCHIENALETTO motorized is a versatile and reliable product, available in different configurations. The backrest support allows to increase the depth of the seat, depending on the user's needs. The available

strokes are: 250 mm, 300 mm and 400 mm. The motorized movement allows to reach a wide range of positions, carefully designed to guarantee the maximum comfort for the end client.

## Optional

STROKE CONFIGURATIONS ↔ 250mm	HEIGHT CONFIGURATIONS ↕ 250mm	ELECTRIC KIT 	CONTROL SYSTEM 
300mm ↔	150mm ↕	ACTUATORS 	BUILT IN SWITCHES 
400mm ↔		PLUGS & CABLE EXTENSIONS 	CONTROL PLATES 
		POWER SUPPLY & BATTERY PACKS 	IPAD/IPOD CONTROL SYSTEM 
		TOUCH SENSOR 	REMOTES 

**Motionitalia Design and quality Made in Italy**

Headquarters: via Navicella 26, 47122 Forlì (FC) Tel. +39 0543 77 47 68 Fax. +39 0543 79 84 09 [www.motionitalia.com](http://www.motionitalia.com) [info@motionitalia.com](mailto:info@motionitalia.com)

The producer reserves the right to modify, at any moment and without notice, the technical specification of its products